

TWEETER LEVEL HIGH / POINT HAUT DU NIVEAU DU HAUT-PARLEUR AIGU

• The polarity of Tweeter indicated on the dividing network is not always the absolute one. L'unité absolue.

• La polarité du haut-parleur d'aigus indiquée dans le circuit diviseur de fréquence n'est pas toujours l'unité absolue.

WIRING CONNECTION/CONNEXION DU CÂBLAGE

Un circuit diviseur de fréquence externe permet un réglage aisé et améliore la qualité du son. reproduction du son avec une distortion extrêmement basse.

Le modèle de référence des séries DDDrive représente un aimant d'injection révolutionnaire pour une reproduction supérieure du son. Cette nouvelle structure du circuit magnétique permet la reproduction.

An external X-over network allows for easy adjustment and high sound quality.

Reference model of DDDrive Series featuring revolutionary injection magnet for superior sound reproduction. This new magnetic circuit structure allows extremely low distortion in sound reproduction.

FEATURES / CARACTÉRISTIQUES

Merci pour avoir acheté un produit ALPINE. Avant de faire toute connexion, lire attentivement ce guide et vous familiariser avec toutes les procédures et illustrations afin d'obtenir des résultats optimaux.

Thank you for purchasing an ALPINE product. Before making any installation, please read this manual thoroughly and familiarize yourself with all procedures and illustrations to insure optimum results.

OWNER'S MANUAL

GUIDE DU PROPRIÉTAIRE

DDC-R17H/DDC-R13H

2-Way Component Speaker System
Système de haut-parleur à 2 voies

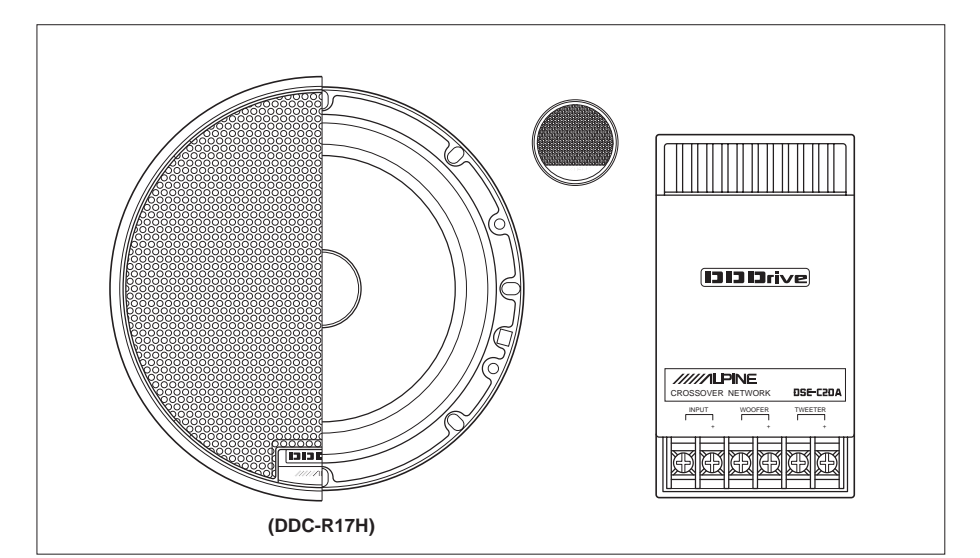

Note : En raison des améliorations qui peuvent être apportées au produit, la fiche technique et la conception son sujet de changement sans préavis.

MODELÉ	DDC-R17H	DDC-R13H
Charge nominale (Pointe).....	150 Watts	120 Watts
Charge nominale (Continue).....	50 Watts RMS	40 Watts RMS
Application recommandée.....	Supérieure à 50 Watts	Supérieure à 40 Watts
Impédance.....	4 ohms	4 ohms
Réponse de fréquence.....	40-35,000 Hz	40-35,000 Hz
Sensibilité.....	89 dBW(1m)	88 dBW(1m)
Matériel du diaphragme.....		
Woofer.....	Neodymium	Neodymium
Tweeter.....	Neodymium	Neodymium
Woofer Free Air Resonance (F ₀).....	63 Hz	65 Hz
Woofer Qms.....	2.48	2.11
Woofer Qms.....	0.58	0.55
Qms du woofer.....	2.48	2.11
Qms du woofer.....	0.76	0.74
Vas du woofer.....	11.8 litres (0.42 cu. ft.)	6.7 litres (0.24 cu. ft.)
Total Moving Mass.....	1.4 kg (3 lbs. 1.4 oz)	1.2 kg (2 lbs. 10.3 oz)
Net Weight (Per Pair).....		
Matériel de montage du woofer.....	Protein Coated Kraft Pulp	Protein Coated Kraft Pulp
Voie Coil Diameter (Woofer).....	30 mm (1.3/16")	30 mm (1.3/16")
Woofer Edge Material.....	Rubber	Rubber
Drop-in Mounting (without spacer).....	52 mm (2-1/16")	47 mm (1-7/8")
Drop-in Mounting (with spacer).....	67 mm (2-5/8")	57 mm (2-1/4")
Magnetic Material.....		
Woofer.....	Neodymium	Neodymium
Tweeter.....	Neodymium	Neodymium
Woofer Free Air Resonance (F ₀).....	63 Hz	65 Hz
Woofer Qms.....	2.48	2.11
Woofer Qms.....	0.58	0.55
Qms du woofer.....	2.48	2.11
Qms du woofer.....	0.76	0.74
Vas du woofer.....	11.8 litres (0.42 cu. ft.)	6.7 litres (0.24 cu. ft.)
Total de masse mouvementée.....	1.4 kg (3 lbs. 1.4 oz)	1.2 kg (2 lbs. 10.3 oz)
Poids net (une paire).....		

Note : Due to continuing product improvement, specifications and design are subject to change without notice.

MODEL	DDC-R17H	DDC-R13H
Power Handling (Peak).....	150 Watts	120 Watts
Power Handling (Continuous).....	50 Watts RMS	40 Watts RMS
Recommended Amplification.....	Up to 50 Watts	Up to 40 Watts
RMS per speaker.....	4 ohms	4 ohms
Frequency Response.....	40-35,000 Hz	45-35,000 Hz
Sensitivity.....	89 dBW(1m)	88 dBW(1m)
Diaphragm Material.....		
Woofer.....	Neodymium	Neodymium
Tweeter.....	Neodymium	Neodymium
Woofer Free Air Resonance (F ₀).....	63 Hz	65 Hz
Woofer Qms.....	2.48	2.11
Woofer Qms.....	0.58	0.55
Qms du woofer.....	2.48	2.11
Qms du woofer.....	0.76	0.74
Vas du woofer.....	11.8 litres (0.42 cu. ft.)	6.7 litres (0.24 cu. ft.)
Total Moving Mass.....	1.4 kg (3 lbs. 1.4 oz)	1.2 kg (2 lbs. 10.3 oz)
Net Weight (Per Pair).....		
Matériel de montage du woofer.....	Protein Coated Kraft Pulp	Protein Coated Kraft Pulp
Voie Coil Diameter (Woofer).....	30 mm (1.3/16")	30 mm (1.3/16")
Woofer Edge Material.....	Rubber	Rubber
Drop-in Mounting (without spacer).....	52 mm (2-1/16")	47 mm (1-7/8")
Drop-in Mounting (with spacer).....	67 mm (2-5/8")	57 mm (2-1/4")
Magnetic Material.....		
Woofer.....	Neodymium	Neodymium
Tweeter.....	Neodymium	Neodymium
Woofer Free Air Resonance (F ₀).....	63 Hz	65 Hz
Woofer Qms.....	2.48	2.11
Woofer Qms.....	0.58	0.55
Qms du woofer.....	2.48	2.11
Qms du woofer.....	0.76	0.74
Vas du woofer.....	11.8 litres (0.42 cu. ft.)	6.7 litres (0.24 cu. ft.)
Total de masse mouvementée.....	1.4 kg (3 lbs. 1.4 oz)	1.2 kg (2 lbs. 10.3 oz)
Poids net (une paire).....		

ALPINE ELECTRONICS, INC.
Tokyo Office : 1-1-8 Nishi Gotanda,
Shinagawa-ku, Tokyo 141, Japan
Tel. : (03) 3494-1101

ALPINE ELECTRONICS OF AMERICA, INC.
19145 Gramercy Place, Torrance,
California 90501 U.S.A.
Tel. : (310) 326-8000

ALPINE ELECTRONICS OF CANADA, INC.
Suite 203, 7300 Warden Ave. Markham,
Ontario L3R 9Z6, Canada
Tel. : (905) 475-7280

ALPINE ELECTRONICS OF AUSTRALIA PTY. LTD.
6-8 Fiveways Boulevard
Keysborough, Victoria 3173, Australia
Tel. : (03) 769-0000

ALPINE ELECTRONICS GmbH
Brandenburger Strasse 2-6 D-40880 Ratingen,
Germany
Tel. : 02102-45 50

ALPINE ITALIA S.p.A.
Via C. Colombo 8, 20090 Trezzano Sul
Naviglio MI, Italy
Tel. : 02-48 40 16 24

ALPINE ELECTRONICS FRANCE S.A.R.L.
(RCS PONTOISE B 338 101 280)
98, Rue De La Belle Etoile, Z.I. Paris Nord II
B.P. 50016 F-95945, Roissy,
Charles De Gaulle Cedex, France
Tel. : 01-48 63 89 89

ALPINE ELECTRONICS OF U.K., LTD.
13 Tanners Drive, Blakelands,
Milton Keynes MK14 5BU, U.K.
Tel. : 01908-61 15 56







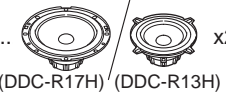

ALPINE ELECTRONICS DE ESPAÑA, S.A.
Portal De Gamarra 36, Pabellón 32
01013 Vitoria(Alava)-Apdo. 133, Spain
Tel. : 34-45-283588

Tech Wah Paper
108 International Road,
Singapore 62917



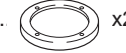







05-30-6012-00
68P90664W61-A
Printed in Singapore (T)





■ Contents/Contenu

For Woofer Mounting/Pour Montage du Woofer



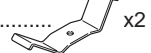

- ① Speaker unit (for woofer use)/ Haut parleur (pour woofer usage)..... x2

- ② Grille/Grille..... x2

- ③ Metal net (for woofer use)/Réseau de mailles métalliques (pour woofer usage)..... x2

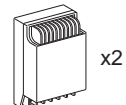
- ④ Rubber pad (for woofer use)/Coussin en caoutchouc (pour woofer usage)..... x2

- ⑤ Spacer ring/Anneau écarteur..... x2

- ⑥ Screw (ø4X30mm)/ Vis (ø4X30mm)..... x8

- ⑦ Screw (ø4X45mm)/ Vis (ø4X45mm)..... x8

- ⑧ Speed clip U type/ Attache de vitesse type U..... x8

- ⑨ Speaker wire/Câble de haut parleur..... x2

For Tweeter Mounting/Pour Montage du Tweeter

- ⑩ Speaker unit (for tweeter use)/ Haut parleur (pour tweeter usage)..... x2

- ⑪ Mounting bracket/Support de montage..... x2

- ⑫ Flush mounting bracket/Support de montage encastré..... x2

- ⑬ Slant spacer/L'écarteur d'inclinaison..... x2

- ⑭ Self-tapping screw (ø4X20mm) / Vis auto-taraudeuse (ø4X20mm)..... x4

- ⑮ Speed nut/Écrou de vitesse..... x4

- ⑯ Self-tapping screw (ø4X8mm) / Vis auto-taraudeuse (ø4X8mm)..... x2

- ⑰ Hexagonal machine screw (M4X20mm) / Vis de machine hexagonale (M4X20mm)..... x2

- ⑱ Hexagonal nut (M4)/Écrou hexagonale (M4)..... x2

- ⑲ Spring washer (M4)/ Rondelle élastique bombée (M4)..... x2

- ⑳ Flat washer(M4)/Rondelle plate(M4)..... x2

- ㉑ Wing nut(M4)/Écrou à ailettes (M4)..... x2

- ㉒ Spring bracket/Support de rondelle..... x2

- ㉓ Sponge cushion (Double side adhesive tape included)/Coussin en éponge (Bande adhésive à deux faces fournie)..... x2

For Network mount/Pour montage de réseau

- ㉔ Network unit/Réseau..... x2

- ㉕ Screw (ø4X20mm)/ Vis (ø4X20mm)..... x4

- ㉖ Speed nut flat type/ Écrou de vitesse type plat..... x4

- ㉗ Network wire/Câble de réseau..... x2

■ Installation procedures/Instructions d'installation

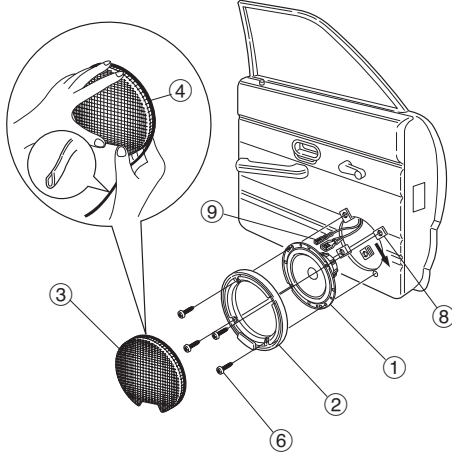
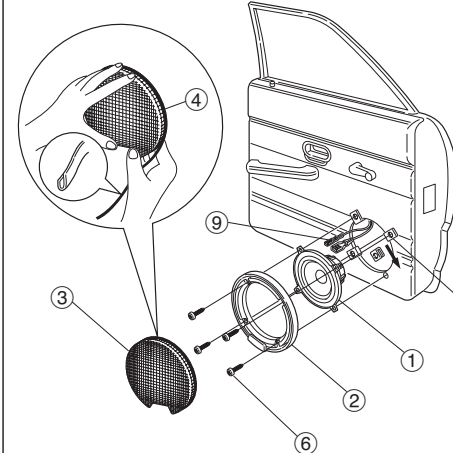
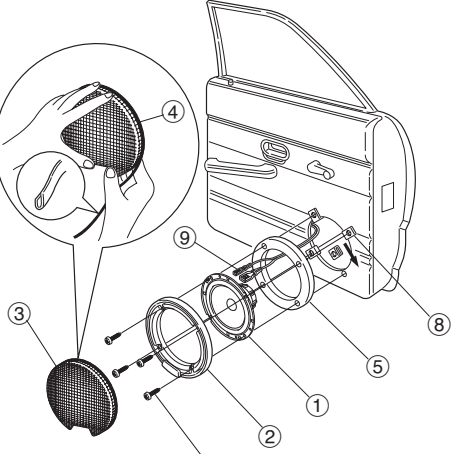
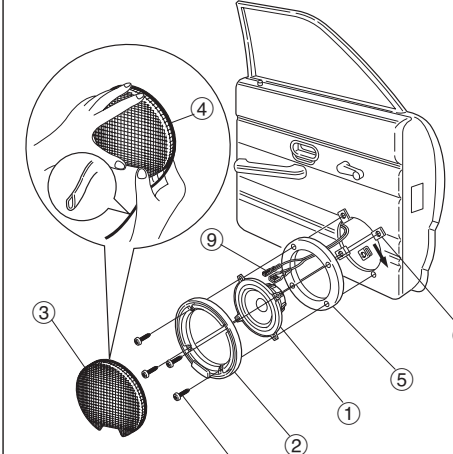
Note: Put the wider side of the rubber pad ④ outside around the metal net ③.

Nota: Mettre le côté large du coussin en caoutchouc ④ au côté extérieur autour du mailles métallique ③.

Woofer installation procedure/Instructions d'installation du woofer

DDC-R17H	DDC-R13H
<p>● Without spacer/Sans écarteur</p> 	<p>● Without spacer/Sans écarteur</p> 
<p>● With spacer/Avec écarteur</p> 	<p>● With spacer/Avec écarteur</p> 

Tweeter installation procedure/Instructions d'installation du tweeter

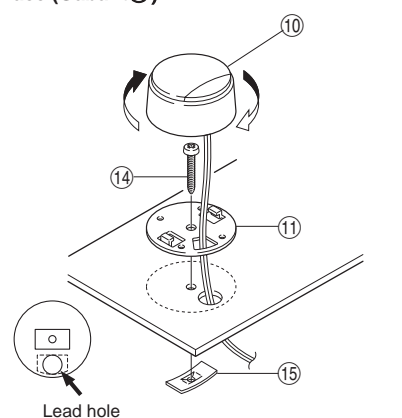
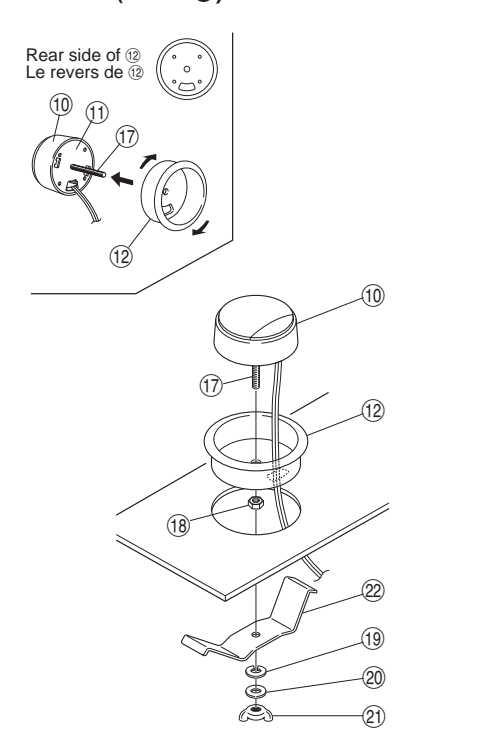
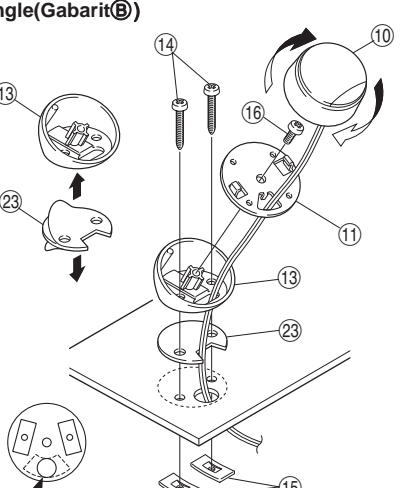
<p>● Surface mounting (Template A) /Montage en surface (Gabarit A)</p>  <p>Lead hole Trou de conducteur</p>	<p>● Flush mounting (Template C) /Montage en encastré (Gabarit C)</p>  <p>Rear side of ⑩ Le revers de ⑩</p>
<p>● Angle mounting (Template B) /Montage en angle (Gabarit B)</p>  <p>Lead hole Trou de conducteur</p>	<p>There is an hexagonal hole at the back of speaker unit ⑩ enter the head of hexagonal screw machine ⑰ and install bracket ⑪ to speaker unit. To lock in place, adjust holes by projecting ⑱ to the back of the flush mounting bracket ⑫ then twist clockwise. (use ⑲ to loose it)</p> <p>Il y a un trou hexagonal à l'arrière de l'unité d'enceinte ⑩ entrer la tête de vis de machine hexagonale ⑰ et installer le support ⑪ à l'unité d'enceinte. Pour verrouiller en place, ajuster les trous en projetant ⑱ vers l'arrière du support de montage encastré ⑫ puis tourner en sens horaire. (utiliser ⑲ pour déverrouiller)</p>

Adjust the direction of the speed nut ⑮ so that it doesn't hinder the hole to use when routing speaker leads.
Ajuster la direction de l'écrou de vitesse ⑮ de manière à ne pas gêner le trou prévu pour guider les conducteurs de haut-parleurs.

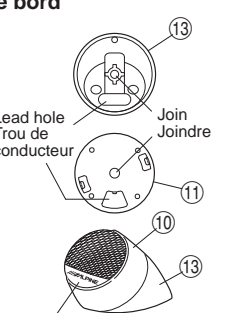
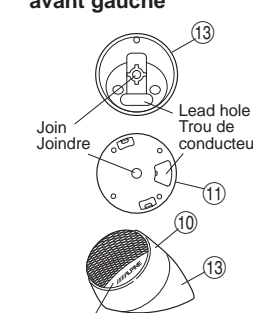
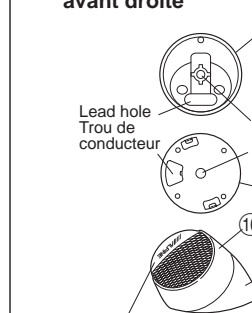

Angle variation (these 3 positions are possible) / Les variations de montage en angle (ces trois positions sont possible)

<p>● On dashboard mounting/ Montage sur le tableau de bord</p>  <p>Lead hole Trou de conducteur</p> <p>Join Joindre</p> <p>Alpine logo position Position du logo Alpine</p>	<p>● Left front door mounting/ Montage sur la portière avant gauche</p>  <p>Join Joindre</p> <p>Lead hole Trou de conducteur</p> <p>Alpine logo position Position du logo Alpine</p>	<p>● Right front door mounting/ Montage sur la portière avant droite</p>  <p>Lead hole Trou de conducteur</p> <p>Join Joindre</p> <p>Alpine logo position Position du logo Alpine</p>
--	---	--

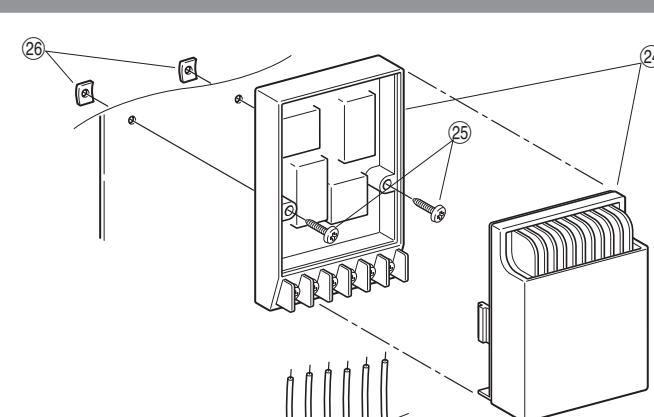
Network installation procedure/Instruction d'installation du réseau

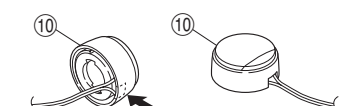

Wire pulled to the front board/Câblage tiré à l'avant du tableau

<p>● Surface mounting/ Montage en surface</p>  <p>Cut the portion pointed by the arrow using a nipper. Découper la portion pointée par la flèche à l'aide d'une pince.</p>	<p>● Angle mounting/ Montage en angle</p>  <p>Route out the wire from the portion pointed by the arrow. Conduire dehors le câble par la portion pointée avec la flèche.</p>
---	--